



USB 2.0 Ranger 140 and USB 2.0 Ranger 440

User Guide



USB 2.0 Ranger 440 Model Shown

powered by [ExtremeUSB](#)→

USB 2.0 Ranger 140 and USB 2.0 Ranger 440

Thank you for purchasing the USB 2.0 Ranger. Please read this guide thoroughly before installation.

This document applies to Part Numbers:

- 00-00185 through 00188. (Ranger 140)
- 00-00208 through 00212. (Ranger 440)

FCC Radio Frequency Interference Statement Warning

The USB 2.0 Ranger 140 and USB 2.0 Ranger 440 have been tested and found compliant with the limits for a Class A digital device, pursuant to Part 15 of the FCC Rules. These limits are designed to provide reasonable protection against harmful interference when installed and operated in a commercial environment. The USB 2.0 Ranger 140 and 440 generates, uses, and can radiate radio frequency energy and, if not installed and used in accordance with this user guide, may cause harmful interference to radio communications. Operation of the USB 2.0 Ranger 140 or 440 in a residential area is likely to cause harmful interference in which case the user will be required to correct the interference at his own expense.

CE Statement

We, Icron Technologies Corporation, declare under our sole responsibility that the USB 2.0 Ranger, to which this declaration relates, is in conformity with European Standard EN 55022/A1 Class A, and EN 50082-1 (IEC 801-2, IEC 801-3, IEC 801-4)

IC Statement

These Class A digital apparatus complies with Canadian ICES-003.

©2006 Icron Technologies Corporation. All rights reserved. Icron Technologies Corporation, the Icron Technologies Corporation logo, and the Icron Technologies Corporation products referred to herein are either the trademarks or the registered trademarks of Icron Technologies Corporation. All other trademarks are property of their respective owners. Icron Technologies Corporation assumes no responsibility for errors that may appear in this manual. Information contained herein is subject to change without notice.

Contents

Introduction.....	1
USB 2.0 Ranger Product Contents.....	1
About the USB 2.0 Ranger 140 and Ranger 440	3
Before You Begin	7
Installing the LEX unit.....	7
Installing the REX unit	7
Connecting the LEX unit to the REX unit	7
Checking the Installation.....	8
Connecting a USB Device	8
Troubleshooting	10
Specifications	12
Limited Hardware Warranty	14
Hardware Remedies	14
Limitation of Liability.....	14
Obtaining Warranty Service.....	15
Contacting Technical Support.....	15

Notes

Introduction

This manual is intended to assist IT professionals install the USB 2.0 Ranger models 140 or 440. The instructions in this guide assume a general knowledge of computer installation procedures, familiarity with cabling requirements, and some understanding of USB devices. The USB 2.0 Ranger reference used for the remainder of this document applies to either the 140 or 440 model.

 **NOTE:** Notes give additional information that could make installation easier.

USB 2.0 Ranger Product Contents

When you open your USB 2.0 Ranger for the first time you should find the following items:

- USB 2.0 Ranger User Guide
- Local EXtender (LEX) unit.
- Remote EXtender (REX) unit.
- AC power adapter (2)
- USB cable (2m long)

To complete the installation, you will also require the following items that are not included with the product:

- USB 2.0 compatible computer
- USB device
- Category 5 Unshielded Twisted Pair (UTP) solid core cable with two RJ45 connectors (if using surface cabling),
OR,
Category 5 UTP cabling with two information outlets and two Category 5 UTP patch cords with RJ45 connectors (if using premise cabling)

 **NOTE:** The maximum length of the Category 5 UTP cable must not exceed 50m. If Cat-5 patch cable is used, total length should not exceed 10m (EIA/TIA-568 specification).

 **NOTE:** All references to Category 5 UTP solid core cable in this document represent the minimum requirement. Category 5E, Category 6 or better UTP or STP cable may be substituted.

USB 2.0 Ranger 140 and USB 2.0 Ranger 440

 **NOTE:** Use only the AC adapters supplied with the USB 2.0 Ranger. The DC supply voltage used on the Ranger 140 or Ranger 440 units is **NOT** the same as Icron Technologies USB 1.1 Ranger products. Use of substitute adapters may cause permanent damage to the system and will void the warranty.

About the USB 2.0 Ranger 140 and Ranger 440

The USB 2.0 Ranger is powered by Icron's *ExtremeUSB*® technology. This technology breaks the five-meter distance barrier for the connection of USB peripheral devices and allows users to enjoy the benefits of USB technology beyond the desktop. With the USB 2.0 Ranger, USB devices can be located up to 50 meters from the host computer.

The USB 2.0 Ranger is composed of two individual units; the LEX unit and the REX unit.

The LEX unit: USB 2.0 Ranger 140 and USB 2.0 Ranger 440

The LEX unit connects to the host computer using a conventional USB cable. It also connects to a power outlet through an AC power adapter. The LEX unit connections are the same for both the 140 and 440 models.

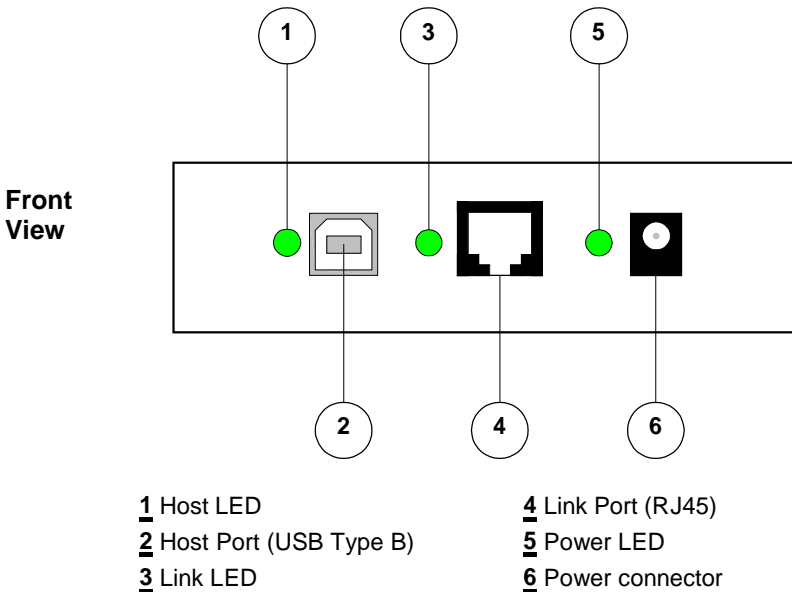

The USB 2.0 Ranger 140 REX unit

The Ranger 140 REX unit provides a single USB device connection at the remote end. Connection to the USB device is via a conventional USB cable. Additional devices may be connected through attachment of a USB Hub at the REX unit. The REX unit is required to be connected to a power outlet through an AC power adapter.

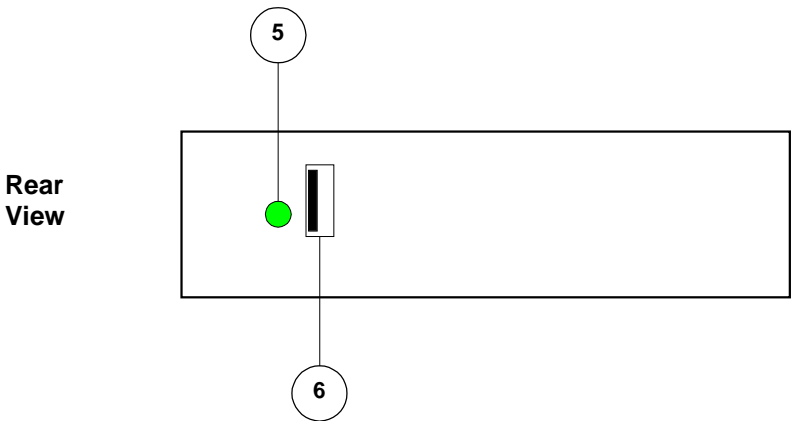
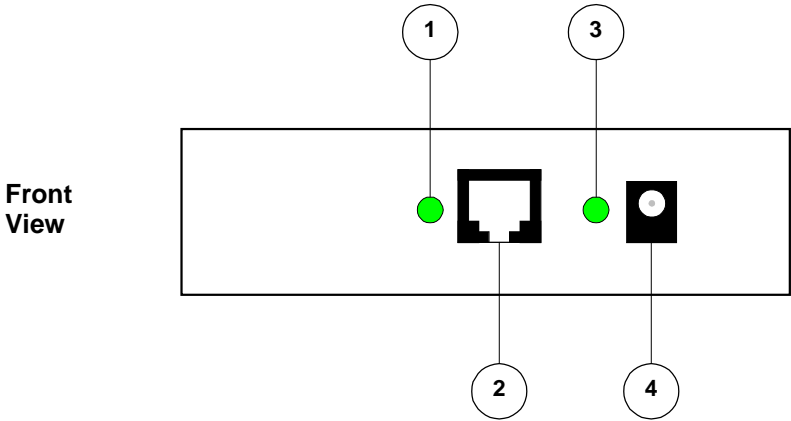

- | | |
|---------------------------|-----------------------------------|
| <u>1</u> Link LED | <u>5</u> Device LED |
| <u>2</u> Link Port (RJ45) | <u>6</u> Device Port (USB Type A) |
| <u>3</u> Power LED | |
| <u>4</u> Power connector | |

The USB 2.0 Ranger 440 REX Unit

The Ranger 440 REX unit integrates a USB Hub and provides four USB device connections the remote end. Connection to the USB device is via a conventional USB cable. Additional devices may be connected through attachment of a USB Hub at the REX unit. The REX unit is required to be connected to a power outlet through an AC power adapter.

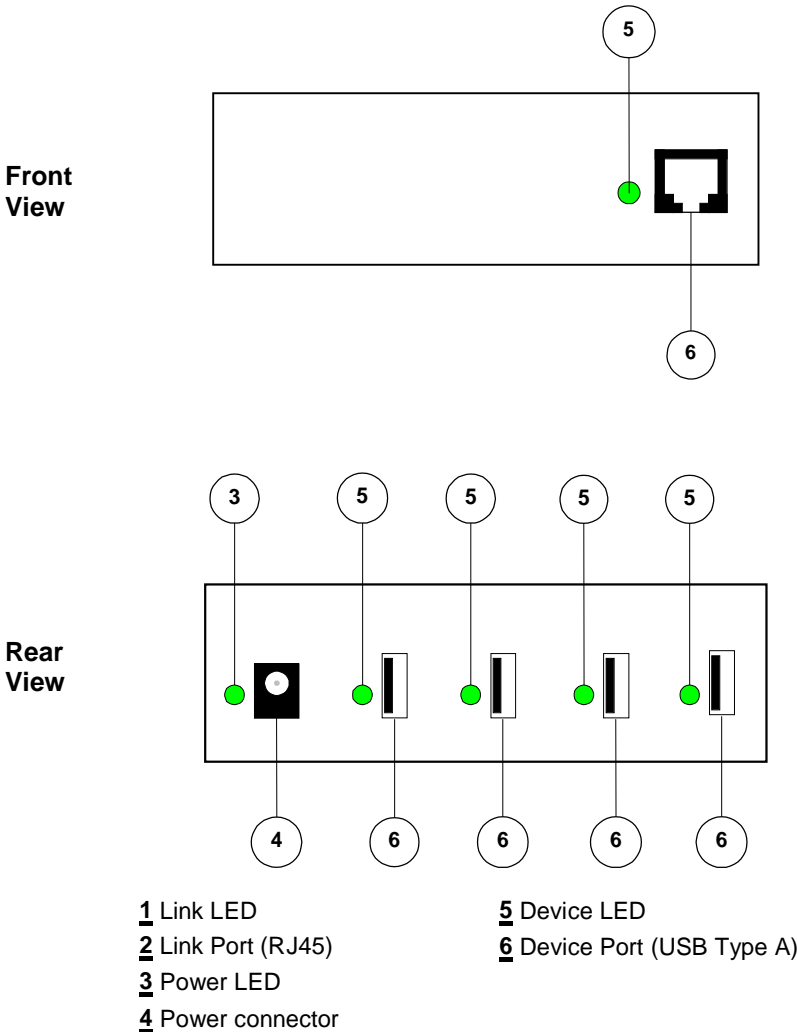

Network Cabling

The LEX unit and REX unit are interconnected by up to 50 meters of Category 5 Unshielded Twisted Pair (UTP) cabling. The UTP cabling must have a straight-through conductor configuration, with no crossovers, and must be terminated with 8-conductor RJ45 connectors at both ends.

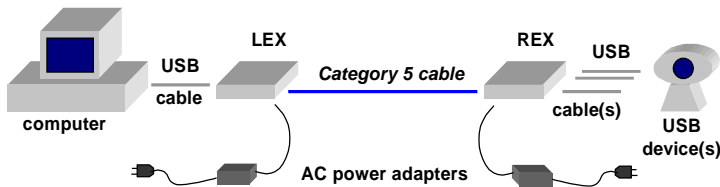

NOTE: Category 5 UTP cabling is the standard data communications cable installed in most commercial and some residential buildings.

USB Cables

USB cables have two distinct connectors. The Type A connector is used to connect the cable from a USB device to the Type A port on a computer or hub. The Type B connector is used to attach the USB cable to a USB device.

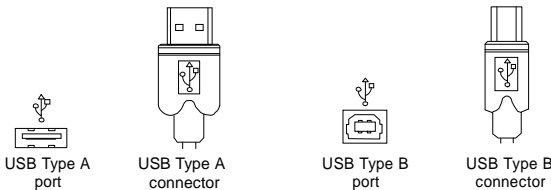

Compatibility

The USB 2.0 Ranger complies with USB 2.0 specifications governing the design of high-speed USB devices. However, Icron Technologies Corporation does not guarantee that all USB devices are compatible with the USB 2.0 Ranger.

Before You Begin

Before you can install the USB 2.0 Ranger, you need to prepare your site.

1. Determine where the host computer is to be located and set up the computer.
2. Determine where you want to locate the USB device(s).
3. If you are using surface cabling, ensure you have enough Category 5 UTP cabling to connect the two locations.

OR

If you are using premise cabling, ensure Category 5 UTP cabling is installed between the two locations, with Category 5 information outlets located near both the computer and the USB device(s).

Installing the LEX unit

1. Place the LEX unit near the host computer.
2. Plug the power adapter into a suitable AC outlet. Ensure the power adapter is compatible with the Ranger 140 and Ranger 440 requirements.
3. Connect the power adapter to the LEX unit.
4. Plug the Type B connector on the USB cable (included) into the Host port on the LEX unit.
5. Plug the Type A connector on the USB cable into the USB port on the computer.

 **NOTE:** The host computer must be equipped with an EHCI (USB 2.0) host controller. Support for OHCI/UHCI (USB 1.1) host controllers is not provided.

Installing the REX unit

1. Place the REX unit near the USB device(s).
2. Plug the power adapter into a suitable AC outlet. Ensure the power adapter is compatible with the Ranger 140 and Ranger 440 requirements.
3. Connect the power adapter to the REX unit.

Connecting the LEX unit to the REX unit

 **NOTE:** To ensure proper operation, we recommend that only Category 5 or better Unshielded Twisted Pair (UTP) solid core cabling be used to connect the LEX unit to the REX unit. The UTP cabling must have

USB 2.0 Ranger 140 and USB 2.0 Ranger 440

a straight-through conductor configuration with no crossovers, and must be terminated with 8-conductor RJ45 connectors at both ends.

With Surface Cabling

1. Plug one end of the Category 5 UTP cabling (not included) into the Link port on the LEX unit.
2. Plug the other end of the Category 5 UTP cabling into the Link port on the REX unit.

With Premise Cabling

1. Plug one end of a Category 5 patch cord (not included) into the Link port on the LEX unit.
2. Plug the other end of the patch cord into the Category 5 information outlet near the host computer.
3. Plug one end of the second Category 5 patch cord (not included) into the Link port on the REX unit.
4. Plug the other end of the second patch cord into the Category 5 information outlet near the USB device.

 **NOTE:** The maximum length of the Category 5 UTP cable must not exceed 50 meters. Cat-5 patch cords must not exceed 10m

Checking the Installation

1. Check that the Power LEDs on the LEX unit and REX unit are both on.
2. Check that the Link LEDs on the LEX unit and REX unit are both on.
3. Check that the Host LED on the LEX unit is on.
4. On the host PC, open the Device Manager applet. Expand the entry for Universal Serial Bus controllers by clicking the + sign. If the USB 2.0 Ranger has been installed correctly you should find it listed as a Generic USB Hub.

Connecting a USB Device

1. Install any software required to operate the USB device(s). Refer to the documentation for the device(s), as required.
2. Connect the USB device to the Device port on the REX unit.

3. Check that the Device LED on the REX unit is on.

Troubleshooting

The following table provides troubleshooting help. The topics are arranged in the order in which they should be executed in most situations. If you are unable to resolve the problem after following these instructions, please contact technical support for further assistance (see page 15).

Symptoms/Cause	Remedy
<p>All LEDs on LEX unit and REX unit are off.</p> <p>Cause:</p> <p>The USB 2.0 Ranger is not receiving power from the adapter</p>	<ol style="list-style-type: none"> 1. Ensure that the power adapters are connected to both the LEX unit and REX unit 2. Check that the adapters are connected to a live source of electrical power
<p>Link LEDs on LEX unit and REX unit are off.</p> <p>Cause:</p> <p>There is no connection between the LEX unit and REX unit.</p>	<ol style="list-style-type: none"> 1. Ensure that a Category 5 UTP cable with straight-through conductors is connected between the LEX unit and REX unit. 2. Connect a short Category 5 patch cord between the LEX unit and REX unit. Recheck the operation of the system.
<p>Link LED on LEX unit is on; Host LED on LEX unit is off.</p> <p>Cause:</p> <ol style="list-style-type: none"> a) The computer is not functioning. b) The LEX unit is not connected to the computer. c) The computer does not support USB 2.0 hubs. d) The USB 2.0 Ranger is malfunctioning. 	<ol style="list-style-type: none"> 1. Disconnect all USB devices from the REX unit. 2. Disconnect the LEX unit from the computer. 3. Disconnect and then reconnect the power adapters to the USB 2.0 Ranger. 4. Reconnect the LEX unit to the computer. 5. In the Universal Serial Bus controllers section of Device Manager, check that the USB 2.0 Ranger is recognised as a "Generic USB Hub". 6. If the USB 2.0 Ranger is not recognised, contact Icron technical support for assistance (see page 15).

Symptoms/Cause	Remedy
<p>A device is connected to REX unit and the corresponding Device LED is off</p> <p>Cause:</p> <ul style="list-style-type: none"> a) The USB device is malfunctioning. b) The computer does not recognise the USB device. c) The application software for the device is not operating. d) The USB 2.0 Ranger is malfunctioning. 	<ol style="list-style-type: none"> 1. Disconnect the USB 2.0 Ranger from the computer. 2. Connect the USB device directly to the USB port on the computer. 3. If the device does not operate properly, consult the user documentation for the device. 4. If the device operates properly when directly connected to the computer, connect another device (of a different type) to the USB 2.0 Ranger. Connect the USB 2.0 Ranger to the computer. 5. If the second device does not operate, the USB 2.0 Ranger may be malfunctioning. Contact technical support for assistance. 6. If the second device does operate properly, the first device may not be compatible with the USB 2.0 Ranger. Contact technical support for assistance.
<p>All LEDs on both the LEX unit and REX unit are on but the device does not operate correctly</p> <p>Cause:</p> <ul style="list-style-type: none"> a) The USB device is malfunctioning. b) The computer does not recognise the USB device. c) The application software for the device is not operating. d) The USB 2.0 Ranger is malfunctioning. 	<ol style="list-style-type: none"> 1. Disconnect the USB 2.0 Ranger from the computer. 2. Connect the USB device directly to the USB port on the computer. 3. If the device does not operate properly, consult the user documentation for the device. 4. If the device operates properly when directly connected to the computer, connect another device (of a different type) to the USB 2.0 Ranger. Connect the USB 2.0 Ranger to the computer. 5. If the second device does not operate, the USB 2.0 Ranger may be malfunctioning. Contact technical support for assistance. 6. If the second device does operate properly, the first device may not be compatible with the USB 2.0 Ranger. Contact technical support for assistance.

Specifications

Range (over Category 5 UTP solid core cable)	50 meters
USB device support	High-speed devices (480 Mb/s) Full speed devices (12 Mb/s) Low speed devices (1.5 Mb/s)
USB host support	EHCI (USB 2.0) only-
AC adapter(s)	Input: 110/240 V AC, 50 – 60 Hz Output: 5 V DC, 3 A Note: Use ONLY the 5V adapters provided with the Ranger 2.0 systems. Other Icron products (USB 1.1 Rangers) use 15V adapters which are not compatible with the Ranger 2.0 systems.
Power available to USB device at REX unit	Ranger 140: 1 x 500 mA Ranger 440: 4 x 500 mA
USB cable	2 meters (6.6 ft)
LEX unit connector (upstream)	1 x USB Type B
LEX unit connector (downstream)	1 x RJ45
REX unit connector (upstream)	1 x RJ45
REX unit connector (downstream)	Ranger 140: 1 x USB Type A Ranger 440: 4 x USB Type A
LEX unit dimensions	107 mm x 84 mm x 34 mm 4.25" x 3.4" x 1.4"
LEX unit weight	0.27 kg (0.6 lb) (140 and 440)
REX unit dimensions	Ranger 140: 107 mm x 84 mm x 34 mm 4.25" x 3.4" x 1.4" Ranger 440: 114mm x 106mm x 38mm 4.5" x 4.2" x 1.5"
REX unit weight	Ranger 140: 0.27 kg (0.6 lb) Ranger 440: 0.32 kg (0.7 lb)

Total system shipping weight	Ranger 140: 1.27kg (2.8 lbs) Ranger 140i – NA: 1.72kg (3.8 lbs) Ranger 140i – EU: 1.81kg (4.0 lbs) Ranger 440: 1.27kg (2.8 lbs) Ranger 440i – NA: 1.72kg (3.8 lbs) Ranger 440i – EU: 1.81kg (4.0 lbs)
Temperature range	4°C to 40°C
Regulatory testing	FCC, CE Class A

Limited Hardware Warranty

Icron Technologies Corporation warrants that any hardware products accompanying this documentation shall be free from significant defects in material and workmanship for a period of one year from the date of purchase. Icron Technologies Corporation's hardware warranty extends to Licensee, its customers and end users.

Hardware Remedies

Icron Technologies Corporation's entire liability and the Licensee's exclusive remedy for any breach of warranty, shall be, at Icron Technologies Corporation's option, either (a) return of the price paid or (b) repair or replacement of hardware, which will be warranted for the remainder of the original warranty period or 30 days, whichever is longer. These remedies are void if failure of the hardware has resulted from accident, abuse, or misapplication.

Limitation of Liability

The hardware warranty set forth in this agreement replaces all other warranties. Icron Technologies Corporation expressly disclaims all other merchantability and fitness for a particular purpose and non-infringement of third-party rights with respect to the hardware. Icron Technologies Corporation dealer, agent, or employee is authorized to make any modification, extension, or addition to this warranty. Under no circumstances will Icron Technologies Corporation, its suppliers or licensors be liable for any costs of procurement or substitute products or services, lost profits, loss of information or data, or any other special, indirect, consequential, or incidental damages arising in any way out of the sale of, use of, or inability to use Icron Technologies Corporation product or service, even if Icron Technologies Corporation, its suppliers or licensors have been advised of the possibility of such damages. In no case shall Icron Technologies Corporation, its suppliers and licensors' liability exceed the actual money paid for the products at issue. Because some jurisdictions do not allow the limitation of implied warranties of liability for incidental, consequential, special, or indirect damages, the above limitation may not always apply. The above limitations will not apply in case of personal injury where and to the extent that applicable law requires such liability.

Obtaining Warranty Service

To obtain warranty service, you must contact Icron Technologies Corporation within the warranty period for a Return Material Authorization (RMA) number. Be sure you have the serial numbers of the LEX unit and REX unit units before calling. Package the product appropriately for safe shipment and mark the RMA number on the outside of the package. The package must be sent prepaid to Icron Technologies Corporation. We recommend that you insure it or send it by a method that provides for tracking of the package. The repaired or replaced item will be shipped to you, at Icron Technologies Corporation's expense, not later than thirty days after Icron Technologies Corporation receives the defective product.

Address the returned product to:

SmartVM

23900 Mercantile Road
Cleveland, Ohio 44122

Tel: 866-999-3210

Contacting Technical Support

If you require technical assistance, send an e-mail message to:

sales@smartvm.com

To help us serve you better, please include the following information with your technical support request:

- Description of the problem
- Host computer make and model
- Type of operating system installed (e.g. Windows XP, Mac OS X, etc.)
- Part number and serial number of the LEX unit and the REX unit
- Make and model of any USB device attached to the USB 2.0 Ranger
- Description of the installation

