



USB 2.0 Ranger 442
and USB 2.0 Ranger 444
User Guide



USB 2.0 Ranger 442 Model Shown

Powered by [ExtremeUSB®](#)

USB 2.0 Ranger 442 and USB 2.0 Ranger 444

Thank you for purchasing the USB 2.0 Ranger. Please read this guide thoroughly before installation.

This document applies to Part Numbers:

- 00-00213 through 00-00217 (Ranger 442)
- 00-00218 through 00-00222 (Ranger 444).

FCC Radio Frequency Interference Statement Warning

The USB 2.0 Ranger 442 and USB 2.0 Ranger 444 have been tested and found compliant with the limits for a Class A digital device, pursuant to Part 15 of the FCC Rules. These limits are designed to provide reasonable protection against harmful interference when installed and operated in a commercial environment. The USB 2.0 Ranger 442 and USB 2.0 Ranger 444 generates, uses, and can radiate radio frequency energy and, if not installed and used in accordance with this user guide, may cause harmful interference to radio communications. Operation of the USB 2.0 Ranger 442 or USB 2.0 Ranger 444 in a residential area is likely to cause harmful interference in which case the user will be required to correct the interference at his own expense.

CE Statement

We, Icron Technologies Corporation, declare under our sole responsibility that the USB 2.0 Ranger 442 and USB 2.0 Ranger 444, to which this declaration relates, are in conformity with European Standard EN 55022/A1 Class A, and EN 50082-1 (IEC 801-2, IEC 801-3, IEC 801-4)

IC Statement

These Class A digital apparatus complies with Canadian ICES-003.

©2006 Icron Technologies Corporation. All rights reserved. Icron Technologies Corporation, the Icron Technologies Corporation logo, and the Icron Technologies Corporation products referred to herein are either the trademarks or the registered trademarks of Icron Technologies Corporation. All other trademarks are property of their respective owners. Icron Technologies Corporation assumes no responsibility for errors that may appear in this manual. Information contained herein is subject to change without notice.

Contents

Introduction.....	1
USB 2.0 Ranger Product Contents.....	1
About the USB 2.0 Ranger.....	2
Before You Begin	5
Installing the LEX unit.....	5
Installing the REX unit	5
Connecting the LEX unit to the REX unit	5
Checking the Installation.....	6
Connecting a USB Device	6
Troubleshooting	7
Specifications	9
Limited Hardware Warranty	11
Hardware Remedies	11
Limitation of Liability.....	11
Obtaining Warranty Service.....	12
Contacting Technical Support.....	12

USB 2.0 Ranger 442 and USB 2.0 Ranger 444

Notes

Introduction

This manual is intended to assist IT professionals install the USB 2.0 Ranger 442 or USB 2.0 Ranger 444. The instructions in this guide assume a general knowledge of computer installation procedures, familiarity with cabling requirements, and some understanding of USB devices. The USB 2.0 Ranger reference used for the remainder of this document applies to either the 442 or 444 model.

 **NOTE:** Notes give additional information that could make installation easier.

USB 2.0 Ranger Product Contents

When you open your USB 2.0 Ranger for the first time you should find the following items:

- USB 2.0 Ranger User Guide
- Local EXtender (LEX) unit.
- Remote EXtender (REX) unit.
- AC power adapter (2 units)
- USB cable (2m long)

To complete the installation, you will also require the following items that are not included with the product:

- USB compatible computer
- USB device
- 2-strand fiber-optic cable with Duplex LC connectors (if using surface cabling),
OR,
2-strand fiber-optic cabling with two information outlets and two 2-strand fiber-optic patch cords with Duplex LC connectors (if using premise cabling)

 **NOTE:** For the USB 2.0 Ranger 442, the maximum length of the multimode fiber-optic (MMF) cable, including patch cords, must not exceed 500m on 50/125 μ m MMF or 300m on 62.5/125 μ m MMF.

 **NOTE:** For the USB 2.0 Ranger 444, the maximum length of the singlemode fiber-optic (SMF) cable, including patch cords, must not exceed 10 km on 9/125 μ m SMF

About the USB 2.0 Ranger

The USB 2.0 Ranger incorporates Icron's *ExtremeUSB*® technology. This technology breaks the five-meter distance barrier for the connection of USB peripheral devices and allows users to enjoy the benefits of USB technology beyond the desktop.

With the USB 2.0 Ranger 442, utilizing multimode fiber, USB devices can be located up to 500 meters from the host computer.

With the USB 2.0 Ranger 444, utilizing singlemode fiber, USB devices can be located up to 10km from the host computer.

The USB 2.0 Ranger is composed of two individual units, the LEX unit and the REX unit. Note that there are no physical differences between the Ranger 442 and Ranger 444 units. The only difference is the Ranger 442 units ship with multimode SFP modules supporting a maximum reach of 500m, and the Ranger 444 units ship with singlemode SFP modules supporting a maximum reach of 10km.

The LEX unit: USB 2.0 Ranger 442 and USB 2.0 Ranger 444

The LEX unit connects to the host computer using a conventional USB cable.

The LEX unit is powered by an external AC adapter.

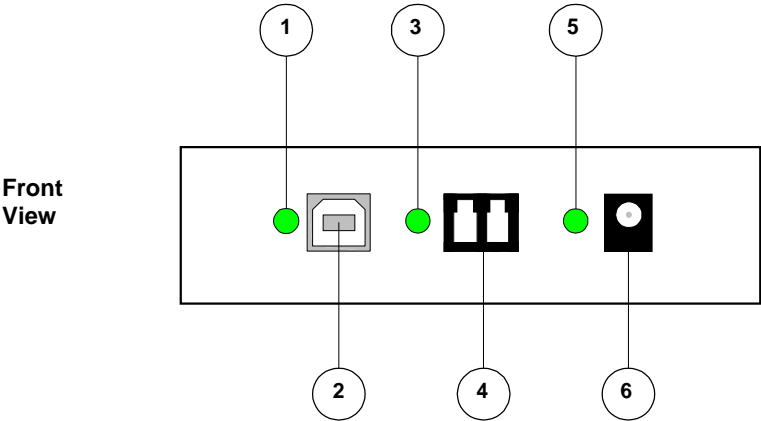

- | | |
|---------------------------------|--------------------------------|
| <u>1</u> Host LED | <u>4</u> Link Port (Duplex LC) |
| <u>2</u> Host Port (USB Type B) | <u>5</u> Power LED |
| <u>3</u> Link LED | <u>6</u> Power connector |

The REX unit: USB 2.0 Ranger 442 and USB 2.0 Ranger 444

The REX unit connects to a USB device using a conventional USB cable. The REX unit allows you to connect up to four USB devices. Additional devices may be connected by attaching a conventional USB hub to the REX unit.

The REX unit is powered by an external AC adapter.

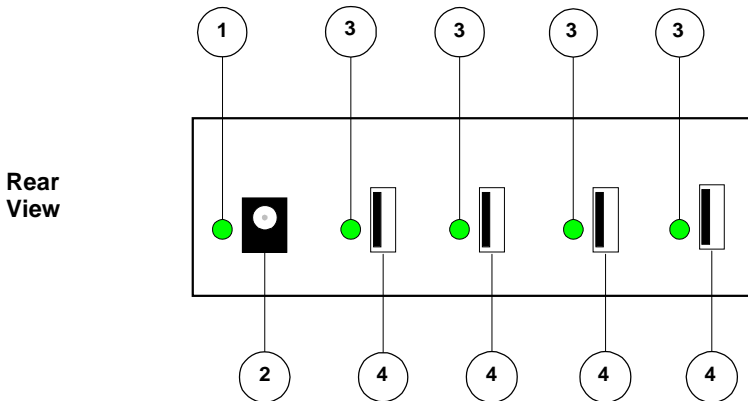
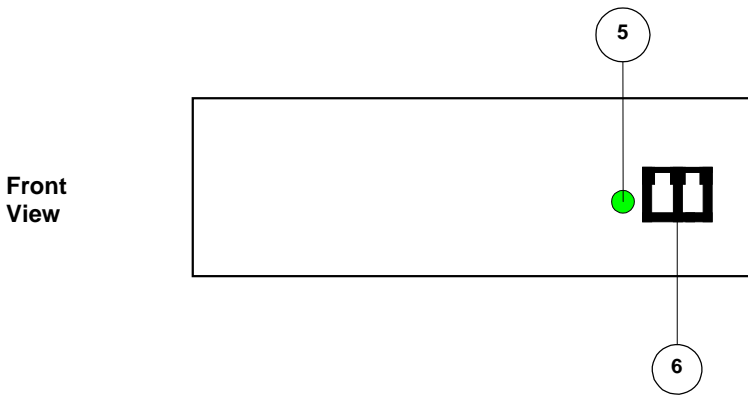

- | | |
|--------------------------|------------------------------------|
| 1 Power LED | 4 Device Ports (USB Type A) |
| 2 Power connector | 5 Link LED |
| 3 Device LEDs | 6 Link Port (Duplex LC) |

Network Cabling

USB 2.0 Ranger 442

The LEX unit and the REX unit are interconnected by up to 500 meters of fiber-optic cabling. Two strands of 50/125µm MMF or 62.5/125µm MMF cabling are required. The cabling subsystem must provide a duplex connection with crossover, and must be terminated with Duplex LC connectors at both ends.

USB 2.0 Ranger 444

The LEX unit and the REX unit are interconnected by up to 500 meters of fiber-optic cabling. Two strands of 9/125µm SMF cabling are required. The cabling subsystem must provide a duplex connection with crossover, and must be terminated with Duplex LC connectors at both ends.

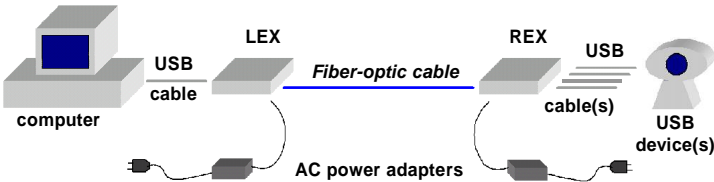

USB Cables

USB cables have two distinct connectors. The Type A connector is used to connect the cable from a USB device to the Type A port on a computer or hub. The Type B connector is used to attach the USB cable to a USB device.

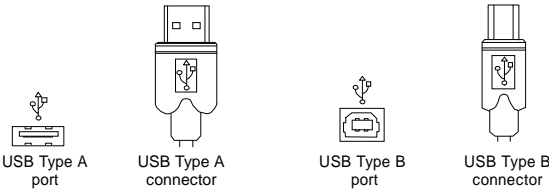

Compatibility

The USB 2.0 Ranger complies with USB 2.0 specifications governing the design of USB devices. However, Icron Technologies Corporation does not guarantee that all USB devices are compatible with the USB 2.0 Ranger.

Before You Begin

Before you can install the USB 2.0 Ranger, you need to prepare your site.

1. Determine where the host computer is to be located and set up the computer.
2. Determine where you want to locate the USB device(s).
3. If you are using surface cabling, ensure you have enough fiber-optic cabling to connect the two locations.

OR

If you are using premise cabling, ensure fiber-optic cabling is installed between the two locations, with fiber-optic information outlets located near both the computer and the USB device.

Installing the LEX unit

1. Place the LEX unit near the host computer.
2. Plug the power adapter into a suitable AC outlet.
3. Connect the power adapter to the LEX unit.
4. Plug the Type B connector on the USB cable (included) into the Host port on the LEX unit.
5. Plug the Type A connector on the USB cable into a USB port on the host computer.

 **NOTE:** The host computer must be equipped with an EHCI (USB 2.0) host controller. Support for OHCI/UHCI (USB 1.1) host controllers is not provided.

Installing the REX unit

1. Place the REX unit near the USB device(s).
2. Plug the power adapter into a suitable AC outlet.
3. Connect the power adapter to the REX unit.

Connecting the LEX unit to the REX unit

With Surface Cabling

1. Plug one end of the fiber-optic cabling (not included) into the Link port on the LEX unit.
2. Plug the other end of the fiber-optic cabling into the Link port on the REX unit.

With Premise Cabling

1. Plug one end of a fiber-optic patch cord (not included) into the Link port on the LEX unit.
2. Plug the other end of the patch cord into the fiber-optic information outlet near the host computer.
3. Plug one end of the second fiber-optic patch cord (not included) into the Link port on the REX unit.
4. Plug the other end of the second patch cord into the fiber-optic information outlet near the USB device.

 **NOTE:** If you are installing a USB 2.0 Ranger 442 unit, the maximum length of the fiber-optic cable, including patch cords, must not exceed 500 meters.

 **NOTE:** If you are installing a USB 2.0 Ranger 444 unit, the maximum length of the fiber-optic cable, including patch cords, must not exceed 10,000 meters.

 **NOTE:** The cabling must provide a duplex connection with crossover, and must be terminated with Duplex LC connectors at both ends.

Checking the Installation

1. Check that the Power LEDs on the LEX unit and the REX unit are both on.
2. Check that the Link LEDs on the LEX unit and the REX unit are both on.
3. Check that the Host LED on the LEX unit is on.
4. On the host PC, open the Device Manager applet. Expand the entry for Universal Serial Bus controllers by clicking the + sign. If the USB 2.0 Ranger has been installed correctly you should find it listed as a Generic USB Hub.

Connecting a USB Device

1. Install any software required to operate the USB device(s). Refer to the documentation for the device(s), as required.
2. Connect the USB device to the Device port on the REX unit.
3. Check that the Device LED on the REX unit is on.

Troubleshooting

The following table provides troubleshooting help. The topics are arranged in the order in which they should be executed in most situations. If you are unable to resolve the problem after following these instructions, please contact technical support for further assistance (see page 12).

Symptoms/Cause	Remedy
<p>All LEDs on LEX unit are off.</p> <p>Cause: The LEX unit is not receiving power from the adapter</p>	<ol style="list-style-type: none"> 1. Ensure that a power adapter is connected to the LEX unit. 2. Check that the adapter is connected to a live source of electrical power.
<p>All LEDs on REX unit are off.</p> <p>Cause: The REX unit is not receiving power from the adapter</p>	<ol style="list-style-type: none"> 1. Ensure that a power adapter is connected to the REX unit. 2. Check that the adapter is connected to a live source of electrical power.
<p>Link LEDs on LEX unit and REX unit are off.</p> <p>Cause: There is no connection between the LEX unit and the REX unit.</p>	<ol style="list-style-type: none"> 1. Ensure that a fiber-optic cable with crossover is connected between the LEX unit and the REX unit. 2. Connect a short fiber-optic crossover patch cord between the LEX unit and the REX unit. Recheck the operation of the system.
<p>Link LED on LEX unit is on; Host LED on LEX unit is off.</p> <p>Cause:</p> <ol style="list-style-type: none"> a) The computer is not functioning. b) The LEX unit is not connected to the computer. c) The computer does not support USB hubs. d) The USB 2.0 Ranger is malfunctioning. 	<ol style="list-style-type: none"> 1. Disconnect all USB devices from the REX unit. 2. Disconnect the LEX unit from the computer. 3. Disconnect and then reconnect the power adapter to the USB 2.0 Ranger. 4. Reconnect the LEX unit to the computer. 5. In the Universal Serial Bus controllers section of Device Manager, check that the USB 2.0 Ranger is recognised as a "Generic USB Hub". 6. If the USB 2.0 Ranger is not recognised, contact technical support for assistance.

Symptoms/Cause	Remedy
<p>A device is connected to the REX unit and the corresponding Device LED is off</p> <p>Cause:</p> <ul style="list-style-type: none"> a) The USB device is malfunctioning. b) The computer does not recognise the USB device. c) The application software for the device is not operating. d) The USB 2.0 Ranger is malfunctioning. 	<ol style="list-style-type: none"> 1. Disconnect the USB 2.0 Ranger from the computer. 2. Connect the USB device directly to the USB port on the computer. 3. If the device does not operate properly, consult the user documentation for the device. 4. If the device operates properly when directly connected to the computer, connect another device (of a different type) to the USB 2.0 Ranger. Connect USB 2.0 Ranger to the computer. 5. If the second device does not operate, the USB 2.0 Ranger may be malfunctioning. Contact technical support for assistance. 6. If the second device does operate properly, the first device may not be compatible with the USB 2.0 Ranger. Contact technical support for assistance.
<p>All LEDs on both the LEX unit and REX unit are on but the device does not operate correctly</p> <p>Cause:</p> <ul style="list-style-type: none"> a) The USB device is malfunctioning. b) The computer does not recognise the USB device. c) The application software for the device is not operating. d) The USB 2.0 Ranger is malfunctioning. 	<ol style="list-style-type: none"> 1. Disconnect the USB 2.0 Ranger from the computer. 2. Connect the USB device directly to the USB port on the computer. 3. If the device does not operate properly, consult the user documentation for the device. 4. If the device operates properly when directly connected to the computer, connect another device (of a different type) to the USB 2.0 Ranger. Connect the USB 2.0 Ranger to the computer. 5. If the second device does not operate, the USB 2.0 Ranger may be malfunctioning. Contact technical support for assistance. 6. If the second device does operate properly, the first device may not be compatible with the USB 2.0 Ranger. Contact technical support for assistance.

Specifications

Range: Ranger 442	500 meters (1650 ft) on 50/125µm MMF 300 meters (1000 ft) on 62.5/125µm MMF
Range: Ranger 444	10,000 meters (33,000 ft) on 9/125µm SMF
USB device support	High-speed devices (480 Mbps) Full-speed devices (12 Mbps) Low-speed devices (1.5 Mbps)
USB host support	EHCI (USB 2.0) only
Power available to USB devices at the REX unit	4 x 500 mA
USB cable	2 meters (6.6 ft)
LEX unit connector (upstream)	1 x USB Type B
LEX unit connector (downstream)	1 x Duplex LC
REX unit connector (upstream)	1 x Duplex LC
REX unit connector (downstream)	4 x USB Type A
LEX unit dimensions	107 mm x 84 mm x 34 mm 4.25" x 3.4" x 1.4"
LEX unit weight	0.3 kg (0.6 lb)
REX unit dimensions	114 mm x 106 mm x 38 mm 4.5" x 4.2" x 1.5"
REX unit weight	0.3 kg (0.6 lb)
Total system shipping weight	1.1 kg (2.4 lb)
Temperature range	4°C to 40°C
Ranger 442 Link cable (not included)	Two strands of 50/125µm MMF or 62.5/125µm MMF cabling are required. The cabling subsystem must provide a duplex connection with crossover, and must be terminated with Duplex LC connectors at both ends.

USB 2.0 Ranger 442 and USB 2.0 Ranger 444

Ranger 444 Link cable (not included)	Two strands of 9/125µm SMF cabling are required. The cabling subsystem must provide a duplex connection with crossover, and must be terminated with Duplex LC connectors at both ends.
Regulatory testing	FCC, CE Class A

Limited Hardware Warranty

Icron Technologies Corporation warrants that any hardware products accompanying this documentation shall be free from significant defects in material and workmanship for a period of one year from the date of purchase. Icron Technologies Corporation's hardware warranty extends to Licensee, its customers and end users.

Hardware Remedies

Icron Technologies Corporation's entire liability and the Licensee's exclusive remedy for any breach of warranty, shall be, at Icron Technologies Corporation's option, either (a) return of the price paid or (b) repair or replacement of hardware, which will be warranted for the remainder of the original warranty period or 30 days, whichever is longer. These remedies are void if failure of the hardware has resulted from accident, abuse, or misapplication.

Limitation of Liability

The hardware warranty set forth in this agreement replaces all other warranties. Icron Technologies Corporation expressly disclaims all other merchantability and fitness for a particular purpose and non-infringement of third-party rights with respect to the hardware. Icron Technologies Corporation dealer, agent, or employee is authorized to make any modification, extension, or addition to this warranty. Under no circumstances will Icron Technologies Corporation, its suppliers or licensors be liable for any costs of procurement or substitute products or services, lost profits, loss of information or data, or any other special, indirect, consequential, or incidental damages arising in any way out of the sale of, use of, or inability to use Icron Technologies Corporation product or service, even if Icron Technologies Corporation, its suppliers or licensors have been advised of the possibility of such damages. In no case shall Icron Technologies Corporation, its suppliers and licensors' liability exceed the actual money paid for the products at issue. Because some jurisdictions do not allow the limitation of implied warranties of liability for incidental, consequential, special, or indirect damages, the above limitation may not always apply. The above limitations will not apply in case of personal injury where and to the extent that applicable law requires such liability.

Obtaining Warranty Service

To obtain warranty service, you must contact Icron Technologies Corporation within the warranty period for a Return Material Authorization (RMA) number. Be sure you have the serial numbers of the LEX unit and the REX unit before calling. Package the product appropriately for safe shipment and mark the RMA number on the outside of the package. The package must be sent prepaid to Icron Technologies Corporation. We recommend that you insure it or send it by a method that provides for tracking of the package. The repaired or replaced item will be shipped to you, at Icron Technologies Corporation's expense, not later than thirty days after Icron Technologies Corporation receives the defective product.

Address the returned product to:

RMA Coordinator
Icron Technologies Corporation
4664 Lougheed Highway, Suite 275
Burnaby, BC, V5C 5T5
Canada
Tel: 604-638-3920

Contacting Technical Support

If you require technical assistance, send an e-mail message to:

techsupport@icron.com

To help us serve you better, please include the following information with your technical support request:

- Description of the problem
- Host computer make and model
- Type of operating system installed (e.g. Windows XP, Mac OS X, etc.)
- Part number and serial number of the LEX unit and the REX unit
- Make and model of any USB device attached to the USB 2.0 Ranger
- Description of the installation



SmartVM

23900 Mercantile Rd
BeachWodd, OH 44122
Toll Free: 866-999-3210
Tel : 216-765-1122
Fax: 216-765-0548
www.smartvm.com